



SUGGESTED LIST PRICE STANDARD EQUIPMENT AND ACCESSORIES

2022 PRICE LIST



REFRESHING THE
EXPERIENCE

EFFECTIVE | APRIL 1, 2022

CUSTOMER SERVICE

GENERAL CONTACT INFORMATION

Customer Service Center
 645 Park East Blvd, Suite 5
 New Albany, IN 47150
 Phone: (800) 367-4233
 Fax: (812) 246-7024

Shipping Location
 1111 Hope Street
 Covington, TN 38019
 Main Phone: (812) 246-7000
 Main Fax: (812) 246-9922

Remit By Mail
 Manitowoc Cayman Funding LTD
 Foodservice Group
 PO Box 204038
 Dallas, TX 75320-4038

SPECIFIC FUNCTION CONTACT INFORMATION

Equipment Orders Fax: (812) 246-7024 bevorders@welbilt.com Hours: 8:00 am – 5:00 pm EST

Technical Service / Service Support / Warranty Phone: (844) 724-2273 Fax: (812) 246-7020 Hours: 8:00 am – 5:00 pm EST

TITLE	NAME	E-MAIL	PHONE EXT.
Customer Service Manager	Alicia Foster	alicia.foster@welbilt.com	3236
Customer Service Representative	Cindy Niles	cindy.niles@welbilt.com	3390
Customer Service Representative	Melissa Hobson	melissa.hobson@welbilt.com	3388
Customer Service Representative	Keri Higgs	keri.higgs@welbilt.com	3259

PRODUCT MANAGEMENT

Product Manager – Multiplex Jenny Ford jennifer.ford@welbilt.com (812) 748-3333

Product Manager – Multiplex Thomas Scotti thomas.scotti@welbilt.com (727) 853-3069

RMA RETURN POLICY

RMA – Returned Product Policy

The following is the policy for Returns from the customer.

1. All returned product must have an RMA number from Customer Service prior to sending the product back.
2. The product must be standard product, still crated and within 90 days from date invoiced. Standard products are defined as product configurations that are saleable to the general market. Custom Products are product configurations that are unique to a specific customer and cannot be sold to other customers. Obsolete/discontinued products cannot be returned.
3. If return is approved for standard product, the standard restock charge is 30% or 20% if a replacement order is made.
4. Custom product is non-returnable.
5. Applicable freight charges and re-creating will be the customer's responsibility.
6. RMA number must be clearly written on all shipping paperwork to factory/warehouse.
7. RMA will be valid for 45 days from date of issue.



Customer Service.....	2	Wall Mount Shelves	31
BEVERAGE EQUIPMENT		Support Stands.....	31
Countertop Beverage Dispensers.....	4-7	Control Panels and Water Regulators	32
Drop-in Beverage Dispensers and Stands	8	Bag-In-Box Pump Panels.....	32
Ice Chests	9	Water Boosters.....	33
Countertop Ice Dispensers	10	Air Compressors	33
Countertop Electric Internal Cold Carbonation Beverage Dispensers.....	10	BEER EQUIPMENT	
Flavor Magic™.....	11	Beer Conduits.....	34
Cup Dispensers	11	High Performance Beer Conduits.....	34
Self Serve Shield.....	12	Conduit Installation Fittings Kits	35
Complete BIB Beverage Installation Kit	13-14	Beermaster™ Glycol Chiller Units	35
Individual Beverage Installation Components	14-16	Beer Pumps and Panels	36
Flomatic® Beverage Valves.....	16	Air Compressor	36
REMOTE REFRIGERATION EQUIPMENT		Beermaster™ Accessories	
Creating a Multiplex Soda or Chiller System	17-18	Empty Beer Detector Kits	36
Refrigeration Unit “Quick-Pick” Selection Chart	19	Conduit Hangar Bracket Kit.....	36
Chiller Selection Charts	20	BLENDED BEVERAGE EQUIPMENT	
Multiplex Soda System Layout.....	21	Fresh Blender	37
Dispensing Towers.....	22-25	NITROGEN INFUSION SYSTEMS	
Model 136.....	22	N2Fusion	38
Model 138.....	23	N2Mobile.....	39
Model 1310.....	24		
Model 158.....	25		
Lid Holders	25		
Beverage Conduit	26-27		
Insulated Conduit.....	26		
Ambient Conduit	27		
Conduit Accessories.....	27		
Refrigeration Units.....	28-31		
Model 2803	28		
Model 11.....	28		
Icecore 44G	28		
Icecore 50G	29		
Model SC180.....	29		
Model SC340	30		
Model SC1000	30		
Model SC2000	30		
Refrigeration Unit Options	31		
Refrigeration Units Accessories.....	31		

COUNTERTOP ICE/BEVERAGE DISPENSERS

SV Series Ice/Beverage Dispenser

(Includes lighted merchandiser with "Quench Your Thirst" graphics, leg kit, key switch, and drain kit)

MODEL/ITEM NUMBER	# OF VALVES	VALVE TYPE	ICE STORAGE	CARBONATOR TYPE	APPROX. SHIP WEIGHT	W	D	H	LIST PRICE
SV-150									
2705020	6	Sanitary Lever	150 lbs	External	227 lbs	23"	31.13"	34.88"	\$6,924
2706071	6	Sanitary Lever	150 lbs	Internal	242 lbs	23"	31.13"	34.88"	\$12,967
SV-175									
2705588	8	Sanitary Lever	175 lbs	External	249 lbs	25"	31.13"	34.88"	\$7,792
2706076	8	Sanitary Lever	175 lbs	Internal	304 lbs	25"	31.13"	34.88"	\$15,012
SV-200									
2705021	8	Sanitary Lever	200 lbs	External	270 lbs	30"	31.13"	34.88"	\$8,140
2706261	8	Sanitary Lever	200 lbs	Internal	315 lbs	30"	31.13"	34.88"	\$15,271
2705485	10	Sanitary Lever	200 lbs	External	274 lbs	30"	31.13"	34.88"	\$8,637
2706080	10	Sanitary Lever	200 lbs	Internal	315 lbs	30"	31.13"	34.88"	\$15,937
SV-250									
2706144	8	Sanitary Lever	250 lbs	External	301 lbs	30"	31.13"	40.88"	\$8,352
2706284	8	Sanitary Lever	250 lbs	Internal	342 lbs	30"	31.13"	40.88"	\$16,064
2706295	10	Sanitary Lever	250 lbs	External	322 lbs	30"	31.13"	40.88"	\$8,877
2706089	10	Sanitary Lever	250 lbs	Internal	342 lbs	30"	31.13"	40.88"	\$17,108



AMERICANS WITH DISABILITIES ACT (ADA) COMPLIANCE

Be sure to ask a Customer Service Representative about Multiplex options to ensure that your location is in compliance with the Americans with Disabilities Act guidelines for beverage dispensers.

COUNTERTOP ICE/BEVERAGE DISPENSERS (CONTINUED)

Flav'R Pic® Series

(Includes multiflavor nozzles, lighted merchandiser with Flav'R Pic graphics, internal carbonation, leg kit, ADA integration and key switch.)

MODEL/ITEM NUMBER	BRANDED FLAVORS	FLAVOR SHOTS	ICE PIC® SELECTABLE ICE	APPROX. SHIP WEIGHT	W	D	H	LIST PRICE
FRP-250								
2705612	16	8	No	378 lbs	30"	31.13"	40.88"	\$24,303
2705663	16	0	No	378 lbs	30"	31.13"	40.88"	\$13,629

MDH Series with Ice Pic® Integrated Ice Crusher without Extended Merchandiser

(Includes Ice Pic® Integrated Ice Crusher, lighted merchandiser with Ice Pic® graphics, key switch, and drain kit)

MODEL/ITEM NUMBER	# VALVES	VALVE TYPE	ICE STORAGE	CARBONATOR TYPE	APPROX SHIP WEIGHT	W	D	H	MERCHANDISER HEIGHT	LIST PRICE
MDH-302 - ICE PIC® INTEGRATED ICE CRUSHER ICE PIC® GRAPHICS										
2706215	12	Sanitary Lever	No	External	479 lbs	42.75"	30.5"	33.25"	12"	\$26,052
2706107	12	Sanitary Lever	No	Cold	485 lbs	42.75"	30.5"	33.25"	12"	\$28,942
MDH-402 - ICE PIC® INTEGRATED ICE CRUSHER ICE PIC® GRAPHICS										
2705988	20	Sanitary Lever	No	External	620 lbs	60"	30.5"	32.25"	12"	\$33,301
2706124	20	Sanitary Lever	No	Cold	640 lbs	60"	30.5"	32.25"	12"	\$36,190
MDH-302 - WITHOUT ICE PIC®, WITH "QUENCH YOUR THIRST" GRAPHICS										
2705668	12	Sanitary Lever	No	External	428 lbs	42.75"	30.5"	33.25"	12"	\$13,423
2705520	12	Sanitary Lever	No	Cold	485 lbs	42.75"	30.5"	33.25"	12"	\$24,546
MDH-402 - WITHOUT ICE PIC®, WITH "QUENCH YOUR THIRST" GRAPHICS										
2706231	20	Sanitary Lever	No	External	602 lbs	60"	30.5"	32.25"	12"	\$16,908
2706116	20	Sanitary Lever	No	Cold	619 lbs	60"	30.5"	32.25"	12"	\$31,661



AMERICANS WITH DISABILITIES ACT (ADA) COMPLIANCE

Be sure to ask a Customer Service Representative about Multiplex options to ensure that your location is in compliance with the Americans with Disabilities Act guidelines for beverage dispensers.

COUNTERTOP ICE/BEVERAGE DISPENSERS (CONTINUED)

MDH Series with Ice Pic® Integrated Ice Crusher - Configured for Extended Merchandiser

(Includes Ice Pic® Integrated Ice Crusher, key switch, and drain kit)

These units are configured for an extended merchandiser, select from merchandiser options below.

MODEL/ITEM NUMBER	# VALVES	VALVE TYPE	ICE STORAGE	CARBONATOR TYPE	APPROX SHIP WEIGHT	W	D	H	MERCHANDISER HEIGHT	LIST PRICE
MDH-302										
2706226	12	Sanitary Lever	300 lbs	External	470 lbs	42.75"	30.5"	33.25"	23.81"	\$26,052
2706112	12	Sanitary Lever	300 lbs	Cold	485 lbs	42.75"	30.5"	33.25"	23.81"	\$28,942
MDH-402										
2706246	20	Sanitary Lever	400 lbs	External	620 lbs	60"	30.5"	32.25"	33.81"	\$33,301
2706128	20	Sanitary Lever	400 lbs	Cold	635 lbs	60"	30.5"	32.25"	33.81"	\$36,190
MDH-402 - DUAL ICE PIC®										
2705984	20	Sanitary Lever	400 lbs	External	626 lbs	60"	30.5"	32.25"	33.81"	\$38,825

MDH Series Ice/Beverage Dispensers Configured for Extended Merchandiser

(Includes key switch, and drain kit) - These units are configured for an extended merchandiser, select from merchandiser options below.

MDH-302 - CONFIGURED FOR EXTENDED MERCHANDISER										
2706221	12	Sanitary Lever	300 lbs	External	425 lbs	42.75"	30.5"	33.25"	23.81"	\$21,658
2706100	12	Sanitary Lever	300 lbs	Cold	485 lbs	42.75"	30.5"	33.25"	23.81"	\$24,546
MDH-402 - CONFIGURED FOR EXTENDED MERCHANDISER										
2706240	20	Sanitary Lever	400 lbs	External	602 lbs	60"	30.5"	32.25"	33.81"	\$28,771
2706120	20	Sanitary Lever	400 lbs	Cold	635 lbs	60"	30.5"	32.25"	33.81"	\$31,661



MODEL/ITEM NUMBER	DETAILS	W	H	LIST PRICE
MDH-302 - ICE PIC® INTEGRATED ICE CRUSHER				
2706176	MDH302 EXM24 IP	42.5"	23.81"	\$1,965
2705278	MDH302 EXM24 QT	42.5"	23.81"	\$1,965
2705970	MDH402 EXM24 IP	59.75"	23.81"	\$2,439
2705415	MDH402 EXM24 QT	59.75"	23.81"	\$2,439
2705238	MDH302 EXM34 IP	42.5"	33.81"	\$3,340
2705135	MDH302 EXM34 QT	42.5"	33.81"	\$3,340
2704607	MDH402 EXM34 IP	59.75"	33.81"	\$4,166
2705053	MDH402 EXM34 QT	59.75"	33.81"	\$4,166
020005155	4" Leg Kit MDH302			\$1,785
020005156	4" Leg Kit MDH402			\$1,885
020005139	Lever Sanitary Molded Ada			Call for Price

AMERICANS WITH DISABILITIES ACT (ADA) COMPLIANCE

Be sure to ask a Customer Service Representative about Multiplex options to ensure that your location is in compliance with the Americans with Disabilities Act guidelines for beverage dispensers.

COUNTERTOP ICE/BEVERAGE DISPENSERS (CONTINUED)

S/SV-SERIES ADAPTER KITS FOR TOP-MOUNTED ICE MACHINE APPLICATIONS

BEVERAGE DISPENSER

ICE MACHINE

	S/SV-150	SV-175	S/SV-200 - S/SV/FRP-250
22" Wide Manitowoc Cuber and Nugget Ice Machine	SL26-020000245 \$693	SL20-020000196 \$693	SL16-5031149 \$724
30" Wide Manitowoc Cuber and Nugget Ice Machine	N/A	N/A	SL36-020001311 \$405
22" Wide Non-Manitowoc Ice Machine	SL26-020000245 \$693	SL20-020000196 \$693	SL25-5031609 \$693
30" Wide Non-Manitowoc Ice Machine	N/A	N/A	SL36-020001311 \$405
Manitowoc IB	IB10-5013398 \$727	N/A	IB13-5013505 \$727
Scotsman Prodigy	SL27-020000246 \$946	IB10-5013398 \$727	SL17-5031150 \$810
Cornelius 15" Nugget*	N/A	SL23-020000199 \$810	SL18-5031151 \$794
Scotsman 21" Nugget*	SL28-020000247 \$841	SL20-020000196 \$693	SL19-5031152 \$1,161
Side Splash Guards	5031157 \$456	5031157 \$456	5031157 \$456

NOTE: The ice/beverage adapter kits listed above contain all the required components for top mounting Manitowoc and non-Manitowoc ice machines. For details regarding the kit contents please contact your Customer Service Representative. 22" Manitowoc RNS units on S/SV200/250 should use a 5031609 - \$693.

*Nugget agitator (020001847 - \$414) and Ice Level Management Kit (5028738 - \$922) required with nugget ice machine applications.

MDH-SERIES ADAPTER KITS FOR TOP-MOUNTED ICE MACHINE APPLICATIONS

BEVERAGE DISPENSER

ICE MACHINE

	MDH-302 Merchandiser		MDH-302 w/Extended Merchandiser		MDH-402		MDH-402 w/Extended Merchandiser	
30" (76.2 cm) wide Manitowoc I-Series and S-Series QuietQube Ice Machine	N1-5003339 SL3-5003674 CL12-020000306	\$446 \$383 \$287	N1-5003339 SL4-5006787	\$446 \$406	N1-5003339 SL5-5009415 CL13-020000121	\$446 \$383 \$111	N1-5003339 SL5-5009415	\$446 \$383
48" (122 cm) Wide Manitowoc Cuber and Nugget Ice Machine	N/A		N/A		SL6-5009414 CL13-020000121	\$399 \$111	SL6-5009414	\$399
One (1) Manitowoc 22" (55.9 cm) wide IB Series Ice Machine	IB5-5011135 CL12-020000306	\$679 \$287	IB4-5011134	\$684	IB6-5011136 CL13-020000121	\$768 \$111	IB7-5011137	\$1,019
Two (2) Manitowoc 22" (55.9 cm) wide IB Series Ice Machine	N/A		N/A		IB8-5011138 CL13-020000121	\$1,038 \$111	IB9-5011139	\$1,026
30" (76.2 cm) wide Non-Manitowoc Ice Machine*	N1-5003339 SL3-5003674 CL12-020000306	\$446 \$383 \$287	N1-5003339 SL4-5006787	\$446 \$406	SL5-5009415 CL13-020000121 N1-5003339	\$383 \$111 \$446	N1-5003339 SL5-5009415	\$446 \$383
30" (76.2 cm) wide Manitowoc Nugget Ice Machine*	N1-5003339 SL3-5003674 CL12-020000306	\$446 \$383 \$287	N1-5003339 SL4-5006787	\$446 \$406	N/A		N/A	

*Nugget agitator (020002125 - \$516) and Ice Level Management Kit (5028738 - \$922) required with nugget ice machine applications.

ITEM DETAILS
 CL Required ice machine lid for top-mounted ice machine applications. Lid covers dispenser manual fill area. (This price is only available for the above (CL) part numbers.)
 SL Required strip lid assembly to top mount an ice machine that is narrower than the dispenser.
 N Required ice deflector to top mount an ice machine.
 IB Required adapter kit to top mount Manitowoc IB Series ice machine on Servend dispenser. NOTE: IB adapter kits may be ordered through either MBE or Manitowoc Ice.

NOTE: When top mounting Servend's Ice/Beverage Dispensers with non-Manitowoc brand ice machines, be sure to check ice machine manufacturer's current product specifications (including ice zone drop areas) to ensure compatibility. Manufacturer's product specifications may change without notice.

NOTE: Contact your Customer Service Representative for Manitowoc Ice Q-Series adapters.

DROP-IN BEVERAGE DISPENSERS

Drop-In Beverage Dispensers

(Includes lighted dual-view™ merchandiser with "Quench Your Thirst" graphics, key switch, and drain kit)

MODEL/ITEM NUMBER	# VALVES	VALVE TYPE	ICE STORAGE	CARBONATOR TYPE	APPROX SHIP WEIGHT	W	D	H	LIST PRICE
DI1522									
2705481	6	Sanitary Lever	60 lbs	External	141 lbs	15"	22"	43.75"	\$4,247
2705936	6	Sanitary Lever	60 lbs	Internal	156 lbs	15"	22"	43.75"	\$8,827
DI2323									
2705189	8	Sanitary Lever	80 lbs	External	206 lbs	23"	23"	42"	\$5,030
2706132	8	Sanitary Lever	80 lbs	Internal	221 lbs	23"	23"	42"	\$10,551



DROP-IN STANDS

DI Stands - Assembled

(Stainless steel, includes 6" leg set)

MODEL/ITEM NUMBER	DETAILS	W	D	HEIGHT INCLUDING LEGS	LIST PRICE
16-1337	Stand Drop-In 15 X 22 Unassembled	18.2"	26.4"	36.1"	\$937
16-1321	Stand Drop-In 23 X 23 Unassembled	25.1"	25.1"	36.1"	\$944

AMERICANS WITH DISABILITIES ACT (ADA) COMPLIANCE

Be sure to ask a Customer Service Representative about Multiplex options to ensure that your location is in compliance with the Americans with Disabilities Act guidelines for beverage dispensers.

ICE CHESTS

(INCLUDES DRAIN KIT)

MODEL/ITEM NUMBER	DETAILS	TOP WIDTH	TOP DEPTH	HEIGHT	BOTTOM WIDTH	BOTTOM DEPTH	LEGS	LIST PRICE
1522								
95-1100-8	1522 Drop-In Post-Mix w/Cold Plate	17.25"	24.29"	14.25"	15"	22"		\$2,248
96-1100-8	1522 Freestanding Post-Mix w/Cold Plate	15.18"	22.18"	14.25"			19.46"	\$2,530
2123								
95-1200-9	2123 Drop In Post-Mix w/Cold Plate	23.3"	25.3"	14.25"	21"	23"		\$2,600
96-1200-9	2123 Freestanding Post-Mix w/Cold Plate	21"	23"	14.25"			19.46"	\$2,835

*SS Legs included with Freestanding units.



MODEL/ITEM NUMBER	DETAILS	LIST PRICE
ICE CHEST LIDS		
5028043	1522 Standard Cover, Outer Welded	\$162
5028042	1522 Standard Cover, Inner Welded	\$116
5028878	1522 Side Sliding, Outer Welded	\$195
5028876	1522 Side Sliding, Inner Welded	\$100
5028047	2123 Standard Cover, Outer Welded	\$197
5028048	2123 Standard Cover, Inner Welded	\$163
030000656	2123 Cover Top, Outer Welded	\$99
030000657	2123 Cover Top, Inner Welded	\$62

NOTE: Complete lids require (1) inner-Welded and (1) Outer-Welded

ICE COMBO CABINET STANDS

MODEL/ITEM NUMBER	DETAILS	LIST PRICE
ICE COMBO CABINET STANDS		
16-1579	Cabinet Stand 30" Ice Combo	\$1,138

COUNTERTOP ICE DISPENSERS

M-Series Countertop Ice Dispensers

(Includes "Ice" graphics, Ice Dispense, leg kit and drain kit)

MODEL/ITEM NUMBER	ICE DISPENSE	ICE STORAGE	WATER VALVE	APPROX. SHIP WEIGHT	W	D	H	LIST PRICE
M45								
2706335	Sanitary Lever	45 lbs	No	69 lbs	15"	28"	24.25"	\$4,969
2706334	Sanitary Lever	45 lbs	Yes	69 lbs	15"	28"	24.25"	\$5,258
M90								
2706332	Sanitary Lever	90 lbs	No	94 lbs	15"	28"	32"	\$5,740
2706331	Sanitary Lever	90 lbs	Yes	94 lbs	15"	28"	32"	\$6,029



S-Series Countertop Ice and Beverage Dispensers

(Includes "Ice" graphics, leg kit, key switch, and drain kit)

MODEL/ITEM NUMBER	ICE DISPENSE	ICE STORAGE	WATER VALVE	APPROX. SHIP WEIGHT	W	D	H	LIST PRICE
S150								
2705519	Sanitary Lever	150 lbs	No	155 lbs	23"	31.3"	34.88"	\$6,450
2704811	Sanitary Lever	150 lbs	Yes	155 lbs	23"	31.3"	34.88"	\$6,980
S200								
2705138	Sanitary Lever	200 lbs	No	205 lbs	30"	31.3"	34.88"	\$7,190
2705515	Sanitary Lever	200 lbs	Yes	205 lbs	30"	31.3"	34.88"	\$7,718
S250								
2705514	Sanitary Lever	250 lbs	No	220 lbs	30"	31.3"	40.88"	\$8,413
2705723	Sanitary Lever	250 lbs	Yes	220 lbs	30"	31.3"	40.88"	\$8,944



COUNTERTOP ELECTRIC INTERNAL CARBONATION BEVERAGE DISPENSERS

Countertop Electric Dispensers

(Includes stainless steel merchandiser, leg kit, key switch, and drain kit)

MODEL/ITEM NUMBER	# OF VALVES	VALVE TYPE	ICE STORAGE	CARBONATOR TYPE	APPROX. SHIP WEIGHT	W	D	H	LIST PRICE
CEV30									
2706458	6	Sanitary Lever	30 lbs	Internal	173 lbs	20.5"	28.16"	29.88"	\$9,852
CEV30 JUICE									
2703527	6	Sanitary Lever	30 lbs	Internal	173 lbs	20.5"	28.16"	29.88"	\$8,312
CEV40									
2706459	8	Sanitary Lever	30 lbs	Internal	173 lbs	25.75"	28.16"	29.88"	\$12,828
MODEL/ITEM NUMBER	TYPE	# VALVES	VALVE TYPE	CARBONATOR TYPE	APPROX. SHIP WEIGHT	W	D	H	LIST PRICE
ALBI									
14-2003-05	Aqua	1	Water	Internal	68 lbs	12.8"	19.7"	19.5"	\$5,095
14-2003-01	All Carb	4	Multiflavor	Internal	68 lbs	13.2"	25"	19.7"	\$6,056



AMERICANS WITH DISABILITIES ACT (ADA) COMPLIANCE

Be sure to ask a Customer Service Representative about Multiplex options to ensure that your location is in compliance with the Americans with Disabilities Act guidelines for beverage dispensers.

FLAVOR MAGIC™

Flavor Magic™ Retrofit Module Kit

Standard features include: Portion control through adjustable dispense time, backlit dispense nozzle with field-selectable flash sequence, built-in dispense counter to track individual flavor sales, POP instruction sheet, and easy-to-install pre-assembled valve and control board modules.

Kit Contents: Switch cover with nozzle, internal nozzle tubing mount, control board and valve solenoid assemblies, nozzle LED, 50 feet of bundled tubing (1 tube for each flavor).

Single Control Module Kits are compatible with single and dual chute dispensers. Dual Control Module Kits are compatible with dual chute dispensers only (MDH-302 and MDH-402).

MODEL/ITEM NUMBER	DETAILS	LIST PRICE
FLAVOR MAGIC™ RETROFIT MODULE KIT		
020001197	3 Flavor Single Control Module for SV Models	\$2,281
020001238	4 Flavor Single Control Module for SV Models	\$2,603
020001169	3 Flavor Single Control Module for MDH Models	\$2,384
020001198	3 Flavor Dual Control Module for MDH Models	\$4,254
020001239	4 Flavor Single Control Module for MDH Models	\$2,624
020001240	4 Flavor Dual Control Module for MDH Models	\$4,468
020001242	8 Flavor Dual Control Module for MDH Models	\$4,924
TUBING		
974-04000X50	Four-Line bundled tubing, sold in 50 foot rolls only	\$8.80/foot
974-04000-01	Four-Line bundled tubing, sold in 100 foot rolls only	\$9.09/foot

CUP DISPENSERS

CD4U Cup Dispenser

Four cup holder tubes (approx. 12 - 44 oz. cups 3³/₈" - 4 5/8" cup diameter) with high volume lid and straw storage. No special cup tube sizes available. CD4U cup dispensers are either free standing, or they can be mounted to the side of MDH Series Ice/Beverage dispensers via drain pan pin. The maximum foam cup diameter on a CD4U is 3 7/8". The CD4U can accommodate a paper or plastic cup with a maximum diameter of 4 5/8". Single Control Module Kits are compatible with single and dual chute dispensers. Dual Control Module Kits are compatible with dual chute dispensers only (MDH-302 and MDH-402).

MODEL/ITEM NUMBER	DETAILS	SIDE OF DISPENSER	W	D	H	LIST PRICE
FOUR CUP HOLDER TUBES WITH HIGH VOLUME LID AND STRAW STORAGE						
5028069	Stainless steel, right with 4 large tubes for 32 oz - 44 oz cups	Right (CD4U-R)	13.125"	22.5"	33"	\$3,709
5028070	Stainless steel, left with 3 large tubes for 32 oz - 44 oz cups and 1 small tube for 20 oz cups	Left (CD4U-L)	13.125"	22.5"	33"	\$3,709
TWO CUP HOLDER TUBES WITH STORAGE AREAS FOR LID, SUGAR, CREAM, AND STIRS						
2733001	CD2X-C - One 2 3/4" - 3 3/8" cup diameter heavy spring loaded cup tube; One 3 1/4" - 3 5/8" cup diameter heavy spring loaded cup tube. 6"W x 23"D x 22½"H	Right or Left	8.375"	23.5"	22.75"	\$2,678
THREE CUP HOLDER TUBES WITH STORAGE AREAS FOR LID, SUGAR, CREAM, AND STIRS						
2741001	CD3A-C - Two 3 1/4" - 3 5/8" cup diameter gravity cup tube; One 4" - 4 3/4" cup diameter gravity cup tube. 6"W x 24"D x 26½"H	Right or Left	8.375"	23.5"	29.375"	\$3,479

*Approximate ship weight for items sold separately without pallets. NOTE: Special Order items, require a minimum order quantity of 10

AMERICANS WITH DISABILITIES ACT (ADA) COMPLIANCE

Be sure to ask a Customer Service Representative about Multiplex options to ensure that your location is in compliance with the Americans with Disabilities Act guidelines for beverage dispensers.

SELF-SERVE SHIELD

Self Serve Shield

Protects the valves and dispense area from airborne particles, easy to install and remove for cleaning.

MODEL/ITEM NUMBER	DETAILS	APPROX. SHIP WEIGHT	W	D	H	LIST PRICE
SV MODEL SELF-SERVE SHIELD						
020008457	Self-Serve Shield for SV150	6 lbs	23.9"	15.6"	14.8"	\$320
020008454	Self-Serve Shield for SV175	6 lbs	25.9"	15.6"	14.8"	\$321
020008455	Self-Serve Shield for SV200/250	6 lbs	30.9"	15.6"	14.8"	\$328
MDH MODEL SELF-SERVE SHIELD						
020008458	Self-Serve Shield for MDH302	7 lbs	44.1"	15.7"	14.8"	\$368
020008459	Self-Serve Shield for MDH402	8 lbs	61.3"	15.7"	14.8"	\$529



COMPLETE BIB BEVERAGE INSTALLATION KIT

MODEL/ITEM NUMBER	DETAILS	APPROX. SHIP WEIGHT	LIST PRICE
6 VALVE COMPLETE BIB INSTALLATION KIT			
020008233	<p>"6 Valve Bag-In-Box (NO CARBONATOR) kit includes: (1) 2 Wide x 3 High welded flat rack, (6) Flojet syrup pumps, (1) primary regulator, (1) secondary regulator." BIB Connectors must be ordered separately, listed on page 15.</p> <p>Kit includes beverage installation components for the regulator and ice/beverage dispenser cold plate inlet plumbing: washers, nut and stem assemblies, barbed crosses, barbed tees, and cable ties. Kit also includes the following single line beverage tubing for the regulator, syrup pumps and water hook up: (1) 100' roll of 1/4" braided tubing, (1) 100' roll of 3/8" braided beverage tubing, (1) 25' roll of 3/8" BIB tubing. Beverage tubing for the syrup run (from unit to BIB boxes) must be ordered in addition to this kit - see next item.</p>	117 lbs	\$2,138
974-00080X50	Bundled Beverage Tubing (50' of 8 line) for syrup run from unit to BIB boxes (1) 50' roll of 8 line sealed beverage tubing, 3/8" line. Single line beverage tubing also available - see page 15.	26 lbs	\$10.60/foot

NOTE: To be used with Carbonators E400397 or E200393

8 VALVE COMPLETE BIB INSTALLATION KIT

020008231	<p>8 Valve Bag-In-Box (NO CARBONATOR) kit includes: (1) 2 Wide x 4 High welded flat rack, (8) Flojet syrup pumps, (1) primary regulator, (1) secondary regulator. BIB Connectors must be ordered separately, listed on page 15.</p> <p>Kit includes beverage installation components for regulator and ice/beverage dispenser cold plate inlet plumbing: washers, nut and stem assemblies, barbed crosses, barbed tees and cable ties. Kit also includes the following single line beverage tubing for the regulator, syrup pumps and water hook up: (1) 100' roll of 1/4" braided tubing, (1) 100' roll of 3/8" braided beverage tubing, (1) 25' roll of 3/8" BIB tubing. Beverage tubing for the syrup run (from unit to BIB boxes) must be ordered in addition to this kit - see next item.</p>	121 lbs	\$2,532
974-00100X50	Bundled Beverage Tubing (50' of 10 line) for syrup run from unit to BIB boxes (1) 50' roll of 10 line sealed beverage tubing, 3/8" line. Single line beverage tubing also available - see page 15.	30 lbs	\$12/foot

NOTE: To be used with Carbonators E400397 or E200393

10 VALVE COMPLETE BIB INSTALLATION KIT

020008234	<p>10 Valve Bag-In-Box (NO CARBONATOR) kit includes: (1) 2 Wide x 5 High welded flat rack, (10) Flojet syrup pumps, (1) primary regulator, (1) secondary regulator. BIB Connectors must be ordered separately, listed on page 15.</p> <p>Kit includes beverage installation components for the regulator and ice/beverage dispenser cold plate inlet plumbing: washers, nut and stem assemblies, barbed crosses, barbed tees, and cable ties. Kit also includes the following single line beverage tubing for the regulator, syrup pumps and water hook up: (1) 100' roll of 1/4" braided tubing, (1) 100' roll of 3/8" braided beverage tubing, (1) 50' roll of 3/8" BIB tubing. Beverage tubing for the syrup run (from unit to BIB boxes) must be ordered in addition to this kit - see next item.</p>	136 lbs	\$2,996
974-00120X50	Bundled Beverage Tubing (50' of 12 line) for syrup run from unit to BIB boxes (1) 50' roll of 12 line sealed beverage tubing, 3/8" line. Single line beverage tubing also available - see page 15.	33 lbs	\$13.31/foot

NOTE: To be used with Carbonators E400397 or E200393

COMPLETE BIB BEVERAGE INSTALLATION KIT (CONTINUED)

12 VALVE COMPLETE BIB INSTALLATION KIT

020008232	12 Valve Bag-In-Box (NO CARBONATOR) kit includes: (1) 3 Wide x 4 High welded flat rack, (12) Flojet syrup pumps, (1) primary regulator, (1) secondary regulator. BIB Connectors must be ordered separately, listed on page 15. Kit includes beverage installation components for the regulator and ice/ beverage dispenser cold plate inlet plumbing: washers, nut and stem assemblies, barbed crosses, barbed tees, and cable ties. Kit also includes the following single line beverage tubing for the regulator, syrup pumps and water hook up: (1) 100' roll of ¼" braided tubing, (1) 100' roll of 3/8" braided beverage tubing, (1) 50' roll of 3/8" BIB tubing. Beverage tubing for the syrup run (from unit to BIB boxes) must be ordered in addition to this kit - see next item.	146 lbs	\$3,313
974-00140X50	Bundled Beverage Tubing (50' of 14 line) for syrup run from unit to BIB boxes (1) 50' roll of 14 line sealed beverage tubing, 3/8" line. Single line beverage tubing also available - see page 15.	36 lbs	\$16.83/foot

NOTE: To be used with Carbonators E400397 or E200393

20 VALVE COMPLETE BIB INSTALLATION KIT

020008235	Back Room Package 20 Center Mounted Pump Dual Co2 Pressure Rack (1) 6 Wide x 4 High welded rack, (20) Flojet syrup pumps, (1) Tank mount primary regulator (9 CFM), (2) Secondary regulator and Top shelf, includes fittings, clamps, ¼" hose for CO2, 3/8" hose for water connections. (16 pumps will be on one regulator for fountain drinks. (4) pumps will be on a separate regulator for lower pressure applications) Dimensions: 39" W x 20" D x 82" H BIB Connectors must be ordered separately, listed on page 15.	280 lbs	\$5,959
020008237	16 Soda / 8 Flavor Shot BIB Connectors must be ordered separately, listed on page 15.	300 lbs	\$6,396

24 VALVE COMPLETE BIB INSTALLATION KIT

020008236	BACK ROOM PACKAGE 24 SIDE MOUNT PUMP DUAL CO2 PRESSURE RACK (1) 6 Wide x 5 High welded rack, (24) Flojet syrup pumps, (1) Tank mount primary regulator (9 CFM), (2) secondary regulator and Top shelf, includes fittings, clamps, ¼ hose for CO2, 3/8" hose for water connections. (20 pumps will be on one regulator for fountain drinks 4 pumps will be on a separate regulator for lower pressure applications) Dimensions: 39" W x 20" D x 85" H BIB Connectors must be ordered separately, listed on page 15. NOTE: Syrup boxes are installed in a vertical position. Rack can accommodate 16 five-gallon boxes, 20 three-gallon boxes, or 32-2.5 gallon boxes. Not all syrup flavors are available in all box sizes in all regions of the country. Standard Box Dimensions: 5 Gallon Box 8"H x 11-¼"W x 16"D; 3 Gallon Box 5¾"H x 11¼"W x 16"D; 2.5 Gallon Box 4¼"H x 11¼"W x 16"D	300 lbs	\$6,613
-----------	--	---------	----------------

INDIVIDUAL BEVERAGE INSTALLATION COMPONENTS

Beverage installation kits include installation components for carbonator, ice and beverage dispenser and regulator plumbing: (washers, nut and stem assemblies, barbed cross, barbed tees, clamps, and barbed splicers). Beverage tubing for syrup and carbonator should be ordered separately.

MODEL/ITEM NUMBER	DETAILS	APPROX. SHIP WEIGHT	LIST PRICE
BEVERAGE INSTALLATION KITS			
5008911	Bag-In-Box installation kit - for 6 to 8 valves, post mix	3 lbs	\$240
5008912	Bag-In-Box installation kit - for 10 to 12 valves, post mix	3 lbs	\$336

INDIVIDUAL BEVERAGE INSTALLATION COMPONENTS

MODEL/ITEM NUMBER	DETAILS	APPROX. SHIP WEIGHT	LIST PRICE
BAG-IN-BOX RACKING AND ACCESSORIES			
020008218	Syrup Rack 2/3 Box wide 28"w x 14"h x 17"d	11 lbs	\$142
020008247	Syrup Rack 3/4 Box wide 39"w x 14"h x 17"d	17 lbs	\$198
Includes end caps and connectors			
MCCANN'S CARBONATORS			
43-6002	Standard Flow Carbonator with vented check valve 115V	25 lbs	\$1,207
E200393	Economy Carbonator 220V	25 lbs	\$1,468
E400397	Fastflow Carbonator with ventable check valve 115V	26 lbs	\$970
REGULATORS			
3741	Post-mix primary Bag-in-Box regulator		\$157
YQT-731A1	Post-mix secondary Bag-in-Box regulator		\$130
BEVERAGE TUBING			
Beverage tubing ordered separately to accommodate specific beverage installation requirements Beverage tubing minimum ordering lengths are listed as roll length			
SINGLE LINE BRAIDED BEVERAGE TUBING			
172-04102-77	100' roll of 1/4" beverage tubing - white	5 lbs	\$0.77/foot
172-04502-00	500' roll of 1/4" beverage tubing - white	26 lbs	\$0.74/foot
172-06100-77	100' roll of 3/8" beverage tubing - white	8 lbs	\$1.21/foot
172-06300-00	300' roll of 3/8" beverage tubing - white	25 lbs	\$1.14/foot
BUNDLED BEVERAGE TUBING (BUNDLED LINES OF BEVERAGE TUBING FOR QUICKER INSTALL)			
974-00080-01	100' roll of (8) 3/8" line sealed beverage tubing - recommended for 6 valve units	52 lbs	\$10.09/foot
974-00100-01	100' roll of (10) 3/8" line sealed beverage tubing - recommended for 8 valve units	60 lbs	\$11.97/foot
974-00120-01	100' roll of (12) 3/8" line sealed beverage tubing - recommended for 10 valve units	66 lbs	\$12.90/foot
974-00140-01	100' roll of (14) 3/8" line sealed beverage tubing - recommended for 12 valve units	72 lbs	\$16.51/foot
BIB CONNECTORS			
QCD-II	QCD gray bayonet style		\$26
00211061	Coca-Cola screw-on connector		\$11
33230	Encore Pepsi screw-on connector		\$23
33231	Dr. Pepper connector		\$20

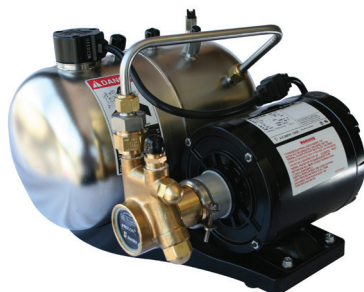

FLOMATIC® BEVERAGE VALVES

(NOTE: Excludes back block)

MODEL/ITEM NUMBER	DETAILS	APPROX. SHIP WEIGHT	W	D	H	LIST PRICE
424 – BEVERAGE (EXCLUDES BACK BLOCK)						
424-CF-E36-1521	1.5 to 3 oz./sec, dual flow controls Sanitary Lever - Molded Plastic	2 lbs	2.5"	4.75"	9"	\$213.14
424-CF-SL36-1521	1.5 to 3 oz./sec, dual flow controls Sanitary Lever - Stainless Steel	2 lbs	2.5"	4.75"	9"	\$237.14
424-CF-S36-1525	1.5 to 3 oz./sec, dual flow controls Push Button	2 lbs	2.5"	4.75"	4.75"	\$216.59
424-CF-A36-1521	1.5 to 3 oz./sec, dual flow controls Automatic Fill Lever	2 lbs	2.5"	4.75"	12"	\$327.18
424-CF-1521	1.5 to 3 oz./sec, dual flow controls Manual Sanitary Lever	2 lbs	2.5"	4.75"	9"	\$165.26
424 – JUICE (EXCLUDES BACK BLOCK)						
424-CF-E36-1521-WI	1.5 to 3 oz./sec dual flow controls HV-Juice Valve (WI) - plastic sanitary lever	2 lbs	2.5"	4.75"	9"	\$244.11
424-CF-E36-1521-WJ	1.5 to 3 oz./sec dual flow controls Juice Valve (WJ) plastic sanitary lever	2 lbs	2.5"	4.75"	9"	\$237.14
424-CF-S36-1525-WJ	1.5 to 3 oz./sec dual flow controls Juice Valve (WJ) push button	2 lbs	2.5"	4.75"	4.75"	\$237.14
424-CF-SL36-1521-WJ	1.5 to 3 oz./sec dual flow controls Juice Valve (WJ) stainless steel sanitary lever	2 lbs	2.5"	4.75"	9"	\$237.14
464 – BEVERAGE (EXCLUDES BACK BLOCK)						
464-GP-E36-1621	2-4 oz./sec: dual flow controls Sanitary Lever - Molded Plastic	2 lbs	2.5"	5.63"	9.5"	\$241.96
464-GP-SL36-1621	2-4 oz./sec: dual flow controls Sanitary Lever - Stainless Steel	2 lbs	2.5"	5.63"	9.5"	\$239.25
464-GP-S36-1625	2-4 oz./sec: dual flow controls Push Button	2 lbs	2.5"	5.63"	5.25"	\$264.65
464-GP-P36-1600	2-4 oz./sec: dual flow controls Portion Control	2 lbs	5.5"	5.63"	5.25"	\$380.70
464-GP-A36-1621	2-4 oz./sec: dual flow controls Automatic Fill Lever	2 lbs	2.5"	5.63"	12.25"	\$369.69
464-GP-1621	2-4 oz./sec: dual flow controls Manual Sanitary Lever	2 lbs	2.5"	5.63"	9.5"	\$180.86
380-Q	Mounting block: .38" inlet port	2 lbs	2.5"	1.2"	2.12"	\$33.91
VARIETY VALVE (MOUNTING BLOCK IS INCLUDED)						
030000069	Autofill	2 lbs	2.5"	5.72"	10.84"	\$1,406.43
030000070	Sanitary Lever	2 lbs	2.5"	5.72"	9.44"	\$1,372.71
030000071	Push Button	2 lbs	2.5"	5.72"	5.45"	\$1,331.96
030000072	Portion Control	2 lbs	2.5"	2.72"	5.45"	\$1,378.32

*Approximate ship weight for items sold separately without pallets.



CREATING A MULTIPLEX SODA OR CHILLER SYSTEM

The information below will allow you to pick beverage system components to satisfy the majority of your prospective customers. There are three main areas that drive the configuration of a soda system.

1 | TYPE, SIZE AND VALVES FOR THE TOWER OR DISPENSING STATIONS

2 | TYPE, SIZE AND LENGTH OF BEVERAGE CONDUIT

3 | TYPE, SIZE AND STYLE (COOLING) OF BEVERAGE REFRIGERATION OR WATER CHILLER UNIT

1 TOWERS OR DISPENSING STATIONS (PAGES 22-25)

There is a wide variety to select from:

A | Style of Dispensing Station

CREW-SWERVE DISPENSING

1. Portion control keyboard.
2. Portion control individual valve covers.
3. Auto fill lever (Foam-over Device).

SELF-SERVE DISPENSING

1. Lever attached.
2. Push button activated.
3. Ice or Ice/Beverage dispenser.

B | What type of valve is required?

- E = Eaton/Wilshire FFV
- L = Lancer/Coca-Cola
- F = Flomatic/Pepsi
- C = Cornelius/Pepsi

2 CONDUIT SELECTION (PAGES 26-28)

SODA CONDUIT:

A | Select insulated conduit by number of lines needed.

1. Number of syrup flavors desired.
2. One plain water for non-carbs and/or water.
3. Two carbonated water lines for Models 28 and 11 (¾" (1 cm) lines required)
4. Two carbonated water lines for Model 42 and Icecore 44G (½" (1.3 cm) lines required)
5. Four carbonated water lines for Icecore 50G (½" (1.3 cm) lines for both syrup and water are recommended).

B | Select non-insulated conduit by number of lines needed.

C | Measure the distance to the closest dispenser and add the distance from that dispenser to all other dispensing stations and add 20 feet (for rise and fall) to obtain your conduit run length.

PRE-CHILLER CONDUIT:

A | Select conduit by number of lines needed.

1. Plain water and carbonated lines required.
2. Insulated or non-insulated conduit required.
3. Measure the distance to the refrigeration unit to be supported and select conduit.

3 SODA REFRIGERATION UNIT (PAGES 29-31)

Selection is based on syrup volume and Towers / Dispensing Stations required. (Use "Quick Pick Selection Chart" pg. 5).

A | Find number of Dispensing Stations.

B | Find the closest business level syrup usage expected.

C | Where the column chosen intersects the business level row you will find the unit required and a maximum conduit length. If your length exceeds the Maximum, go to the right and down (if necessary) until you have found a match for your requirement.

NOTE: Models 2803 and 11 available in air. Icecore 44G and 50G available in air, water and remote cooled. Base your decision on store requirement or preference.

NOTE: See notes below chart referring to climate (75oF / 24oC). Higher than rated ambient temperatures will require you to go to the next larger size Soda Unit or to add a water chiller to reduce incoming water temperatures.

NOTE: **One Syrup Coil is required per flavor** (see additional coil part numbers listed after Soda refrigeration units).

CHILLER REFRIGERATION UNIT Selection is based on three applications: (Use Chiller Selection Chart pg. 6).

A | Remote Recirculation Soda Factory is too small for the application due to incoming water temperature or volume is higher than anticipated.

1. Refer to Chilled Water to Multiplex Soda Factory Unit Applications section in the Chiller Selection Chart pg. 6.
2. Find Soda unit row and move to the right until you see 100%.
3. Find the Water Chiller for your situation.

NOTE: The Model SC340 is capable of reducing incoming water temperatures for all Multiplex Soda units listed. The SC1000 and SC2000 units would be used to Pre-Chill water to multiple Soda Factory Units as shown in the "Max Soda Units Supported" row.

B | Restaurant/Outlet is unwilling or unable to add additional ice making capacity for a **Coldplate Soda Dispenser**.

1. Refer to Chilled Water or Soda to Coldplate Applications section in the Chiller Selection Chart pg. 6.
2. Find capacity row and move to the right until you see the number of 12 oz drinks per minute you will need to support.
3. Find the Water Chiller for your situation.

C | **Bakery or General application** has a requirement for chilled water.

1. Refer to Bakery Applications section in the Chiller Selection Chart pg. 6.
2. Find capacity row and move to the right until you see the numbers of pounds of water required per hour or gallons of water per hour needed to support the process.
3. Find the Water Chiller for your situation.

NOTE: The SC Water Chiller line reduces incoming water temperature from 90oF to 40oF (32.2oC to 4.4oC) at the ratings listed. If the ambient incoming water temperatures are less than 90oF (32.2oC) you will have a proportionate excess of capacity.

4 STAND OR WALL MOUNT RACK (PAGE 33)

Stand or Wall Mount Rack selection is based on the Soda refrigeration units used and by syrup tank or Bag-In-Box syrup storage required.

5 AIR/CO2 CONTROL PANELS AND WATER CONTROLS

Air/CO2 Control Panels and Water Controls are selected based on the use of syrup tanks or Bag-In-Box syrup supplies.

6 BAG-IN-BOX PUMPS (PAGES 34)

A | Minimum one pump per flavor.

B | Fittings required by particular customers.

1. QCD Fittings are used for General line syrups.
2. Coke (Red) fittings are required for Coca-Cola products.

7 TEE KITS, ADAPTER KITS, INSTALLATION ACCESSORIES AND SUPPORT EQUIPMENT (PAGES 28,32,35)

A | How to choose the Tee Kit, Adapter Kit and Installation Accessories required.

1. Check Conduit ordered in step two for tubing sizes included and pick tee fitting kit which matches internal conduit tubing diameters.
2. Add additional adapter kits as necessary (splicers).

NOTE: Number of Conduit Tee Fitting kits required (number of towers or dispensing stations minus one = the number of tee kits required) - model 2803 and 11 have 3/8" water and 1/4" syrup fittings.

3. Select optional conduit straps for in-ceiling installation of conduit.
4. Select optional conduit shrouds to hide conduit in kitchen or customer areas from the ceiling to the counter.

B | Water Boosters are used when incoming water pressures fall below the 40 PSI minimum requirement at any operational time of the day (Proper ratio of the finished beverage is the issue here).

C | **Air Compressors** are used to push tank or Bag-In-Box syrups from the back room to the soda refrigeration unit and eventually to the tower or dispensing station rather than using purchased CO2 gas. (Long term savings of CO2 gas and the ability to serve plain water drinks when the outlet is out of CO2 gas are the benefits.

D | **Remote Condensers** are installed on rooftops or away from the work area and used with remote cooled refrigeration units as a means of venting all the hot air exhausted by the refrigeration compressor. This method is especially beneficial in warm climates where excessive heat or air conditioning loads are not desirable.

E | **Refrigerant Pre-Charged Line Sets** are used to connect the remote soda refrigeration unit to the remote condensers.

NOTE: Measure the run length from refrigeration unit to condenser location (normal allowed elevation without P-trap is 25 feet - if P-trap required, add five feet to refrigerant line length).

REFRIGERATION UNIT "QUICK-PICK" SELECTION CHART

NUMBER OF DISPENSING STATIONS

BUSINESS LEVEL*	1	2	3	4
Up to 6 gal (3 L) of syrup/day or 280 drinks/day (2,000 gal/yr)	MODEL 2803 40 ft (12 m) Maximum Conduit Length	MODEL 11M 100 ft (30 m) Maximum Conduit Length	ICECORE 44G 250 ft (80 m) Maximum Conduit Length	ICECORE 44G 250 ft (80 m) Maximum Conduit Length
Up to 12 gal (45 L) of syrup/day or 560 drinks/day (4,000 gal/year)	MODEL 11M 100 ft (30 m) Maximum Conduit Length	MODEL 11M 100 ft (30 m) Maximum Conduit Length	ICECORE 44G 250 ft (80 m) Maximum Conduit Length	ICECORE 44G 250 ft (80 m) Maximum Conduit Length
Up to 21 gal (79 L) of syrup/day or 980 drinks/day (7,500 gal/year)	ICECORE 44G 250 ft (80 m) Maximum Conduit Length	ICECORE 44G 250 ft (80 m) Maximum Conduit Length	ICECORE 44G 250 ft (80 m) Maximum Conduit Length	ICECORE 44G 250 ft (80 m) Maximum Conduit Length
Up to 32 gal (121 L) of syrup/day or 1,400 drinks/day (11,500 gal/yr)	ICECORE 44G 250 ft (80 m) Maximum Conduit Length	ICECORE 44G 250 ft (80 m) Maximum Conduit Length	ICECORE 50G 350 ft (107 m) Maximum Conduit Length	ICECORE 50G 350 ft (107 m) Maximum Conduit Length
Up to 42 gal (159 L) of syrup/day or 2,000 drinks/day (15,000 gal/yr)	ICECORE 50G 350 ft (107 m) Maximum Conduit Length	ICECORE 50G 350 ft (107 m) Maximum Conduit Length	ICECORE 50G 350 ft (107 m) Maximum Conduit Length	ICECORE 50G 350 ft (107 m) Maximum Conduit Length

*Care must be taken when selecting the proper refrigeration unit. Above selections are for 75oF (24oC) conditions, 16 ounce (470 ml) drinks, and average business cycles. Other factors such as lunch or dinner peak periods, large drinks, or high ambient conditions may require the next larger size unit. Contact your Welbilt authorized distributor for more information.

CHILLER SELECTION CHARTS

Application Details

CHILLER MODEL NUMBER				
	SC180	SC340	SC1000	SC2000
Evaporator Rating (BTUH)	3060	4250	7400	14900
Cabinet Heat Gain (BTUH)	260	361	710	925
Ice Bank Weight (Lb. Avg.)	26.5	50	100	175

Chilled Water to Multiplex Soda Unit Applications

Chiller working at Inlet 90oF (32.2oC) and Outlet 75oF (23.8oC) for 2 hours

CHILLER MODEL NUMBER				
	SC180	SC340	SC1000	SC2000
MAX SODA UNITS SUPPORTED	(1) MODEL 11	(2) MODEL 2803	(1) ICECORE 50G	(2) ICECORE 50G
Capacity increase for Model 2803	100%	100%	100%	100%
Capacity increase for Model 11	90%	100%	100%	100%
Capacity increase for Model 42	96%	100%	100%	100%
Capacity increase for Model 44	96%	100%	100%	100%
Capacity increase for Model 50	67%	100%	100%	100%

NOTE: Any chiller will support the model or models listed or any unit of a lesser capacity.

Chilled Water or Soda to Cold Plate Applications

Number of 12-fl.oz Drinks/Minute supported at Inlet 90oF (32.2oC) and Output 40oF (4.4oC)

CHILLER MODEL NUMBER				
	SC180	SC340	SC1000	SC2000
Two-hour peak at Inlet 90oF (32.2oC)	2.4	4	6.7	12.7
Sustained at Inlet 90oF (32.2oC)	1.6	2.5	3.4	7.2

Bakery Applications

Inlet 90oF (32.2oC) and Outlet 35oF (1.7oC)

CHILLER MODEL NUMBER				
	SC180	SC340	SC1000	SC2000
Two-hour peak at Inlet 90oF (32.2oC) - Lb./Hr.	84.7	141.8	237.6	452
Sustained at Inlet 90oF (32.2oC) - Lb./Hr.	57.2	87.8	121.8	254.4
Two-hour peak - Gal./Hr.	10.2	17	28.5	54.3
Sustained Flow - Gal./Hr.	6.9	10.5	28.5	54.3

(Water weighs 8.3 pounds (3.8 kg) per gallon)

MULTIPLEX SODA SYSTEMS LAYOUT

Numbers and letters on this page refer to specific sections for the specific components. Refer to the extreme left or right hand column on each catalog page.

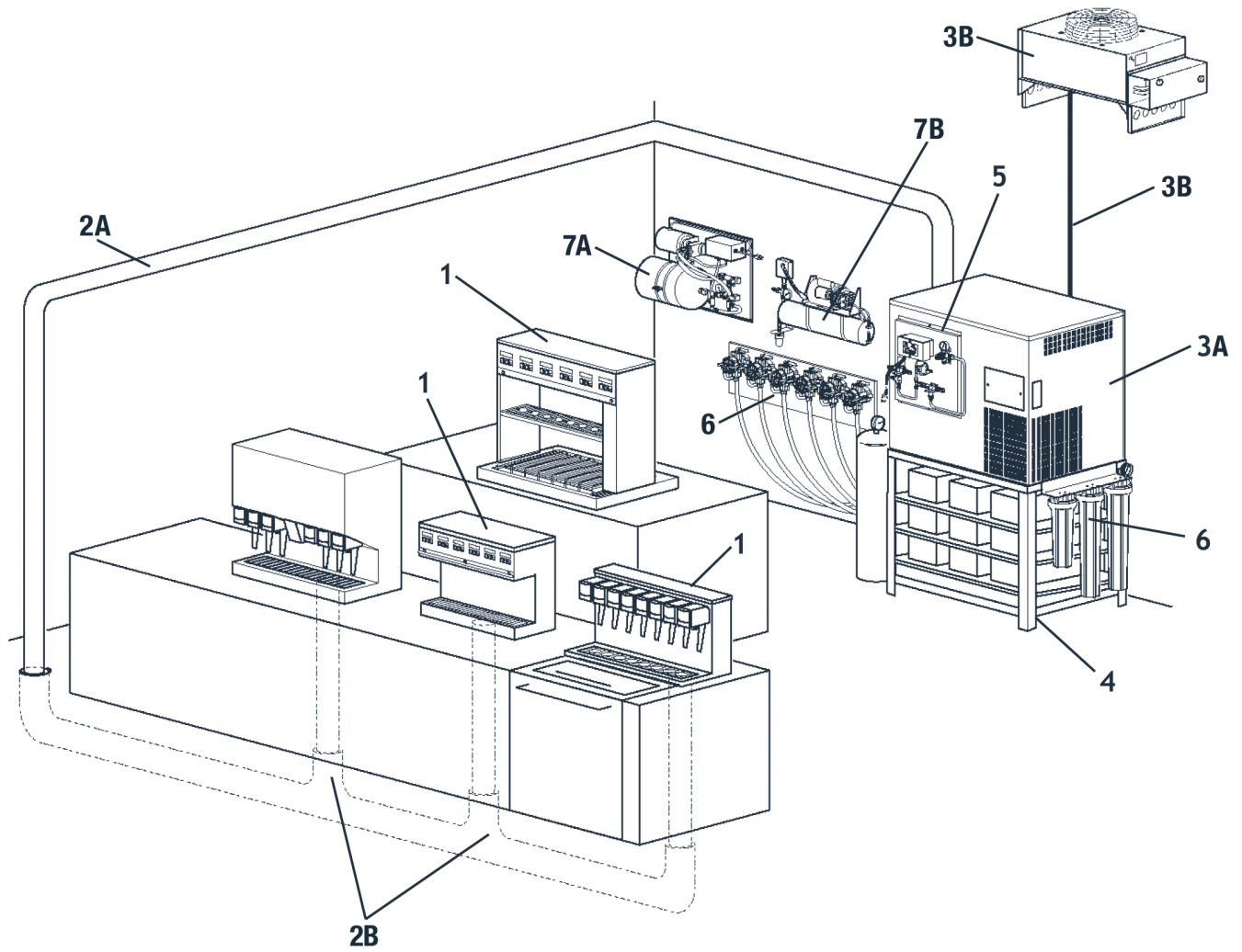

DISPENSING TOWERS

**MODEL 136
6 VALVE TOWERS**

6 Beverage Valves

Manifolded for 5 Carbonated and 1 Non Carbonated Drinks

Includes Calibration Kit

7 1/2" Cup Clearance

EQUIPMENT	PART NO.	DETAILS	APPROX. SHIP WEIGHT	W	D	H	PRICE (\$)
-----------	----------	---------	------------------------	---	---	---	------------

PORTION CONTROL



00913600	MODEL 136EDA Wilshire/Dole FFV 3.0 oz/sec valves single transformer 120 VAC primary, 24 VAC secondary, 50/60 Hz	70 lbs (31.8 kg)	24"	12.25"	17.75"	\$7,313
00913601	MODEL 136EDA Wilshire/Dole FFV 3.0 oz/sec valves single transformer 220 VAC primary, 24 VAC secondary, 50/60 Hz	70 lbs (31.8 kg)	24"	12.25"	17.75"	\$7,482
00913608	MODEL 136LDAX Lancer LVV 3.0 oz/sec valves Single transformer, 230 VAC primary, 24 VAC secondary, 50/60 Hz	70 lbs (31.8 kg)	24"	12.25"	17.75"	\$12,120

SANITARY LEVER

00913674	MODEL 136CDL Cornelius SFV1 3.0 oz/sec valves Single transformer, 120 VAC primary, 24 VAC secondary, 50/60 Hz	70 lbs (31.8 kg)	24"	12.25"	17.75"	\$6,225
-----------------	---	---------------------	-----	--------	--------	----------------

DISPENSING TOWERS (CONTINUED)

1

MODEL 138 8 VALVE TOWERS

8 Beverage Valves

Manifolded for 6 Carbonated and 2 Non Carbonated Drinks

Includes Calibration Kit

7 1/2" Cup Clearance

EQUIPMENT	PART NO.	DETAILS	APPROX. SHIP WEIGHT	W	D	H	PRICE (\$)
PORTION CONTROL							
	00913801	MODEL 138EDA Wilshire/Dole FFV 424 3.0 oz/sec valves, Single transformer, 120 VAC primary, 24 VAC secondary, 50/60 Hz	85 lbs (38.6 kg)	24"	12.375"	17.75"	\$7,981
	00913802	MODEL 138EDAX Wilshire/Dole FFV 424 3.0 oz/sec valves, Single transformer, 220 VAC primary, 50/60 Hz	85 lbs (38.6 kg)	24"	12.375"	17.75"	\$8,244
	00913807	MODEL 138EDAX Wilshire/Dole FFV 3.0 oz/sec valves, Single transformer, 220 VAC primary, 24 VAC secondary, 50/60 Hz	85 lbs (38.6 kg)	24"	12.375"	17.75"	\$8,244
	00913800	MODEL 138EDA2 Wilshire/Dole FFV 3.0 oz/sec valves Two, dual-flavor valves, Single transformer, 120 VAC primary, 24 VAC secondary, 50/60 Hz	85 lbs (38.6 kg)	24"	12.375"	17.75"	\$11,184
	00913809	MODEL 138LDAX Lancer LVV 3.0 oz/sec valves, Dual transformer, 230 VAC primary, 24 VAC secondary, 50/60 Hz	85 lbs (38.6 kg)	24"	12.375"	17.75"	\$16,347
	00913814	MODEL 138LDAX Lancer LVV 3.0 oz/sec valves, Dual transformer, 230 VAC primary, 24 VAC secondary, 50/60 Hz	85 lbs (38.6 kg)	24"	12.375"	17.75"	\$16,347
	00913829	MODEL 138LDAX Lancer LVV 3.0 oz/sec valves, Dual transformer, 230 VAC primary, 24 VAC secondary, 50/60 Hz	85 lbs (38.6 kg)	24"	12.375"	17.75"	\$16,347
	00913893	MODEL 138LDAX Lancer LVV 1.5 oz/sec valves, Dual transformer, 230 VAC primary, 24 VAC secondary, 50/60 Hz	85 lbs (38.6 kg)	24"	12.375"	17.75"	\$16,347

SANITARY LEVER

00913866	MODEL 138LDL Lancer LEV 3.0 oz/sec valves, Single transformer, 120 VAC primary, 24 VAC secondary, 50/60 Hz	85 lbs (38.6 kg)	24"	12.375"	17.75"	\$7,958
----------	---	---------------------	-----	---------	--------	----------------

DISPENSING TOWERS (CONTINUED)

**MODEL 1310
10 VALVE TOWERS**

10 Beverage Valves

Manifolded for 5 Carbonated and 5 Non Carbonated Drinks

Includes Calibration Kit

7 1/2" Cup Clearance

PART NO.	DETAILS	APPROX. SHIP WEIGHT	W	D	H	PRICE (\$)
SANITARY LEVER						
00913101	MODEL 136EDA Wilshire/Dole FFV 3.0 oz/sec valves Single transformer 120 VAC primary, 24 VAC secondary, 50/60 Hz	70 lbs (31.8 kg)	30"	12.375"	17.75"	\$10,530
PORTION CONTROL						
00913102	MODEL 1310EDC Wilshire/Dole FFV 3.0 oz/sec valves Single transformer, 120 VAC primary, 24 VAC secondary, 50/60 Hz	70 lbs (31.8 kg)	30"	12.375"	17.75"	\$16,828

DISPENSING TOWERS (CONTINUED)

1

MODEL 158 10 VALVE TOWERS

8 Beverage Valves

Manifolded for 7 Carbonated and 1 Non Carbonated Drinks

Includes Calibration Kit and Out of CO2 Light

7 1/2" Cup Clearance

PART NO.	DETAILS	APPROX. SHIP WEIGHT	W	D	H	PRICE (\$)
00915826	MODEL 158EDLHX Wilshire/Dole FFV 3.0 oz/sec valves, Single transformer 120 VAC primary 24 VAC secondary, 50/60 Hz	110 lbs (49.9 kg)	26"	17.25"	35.625"	\$12,695
00915828	MODEL 158LDLHX Lancer LVV 3.0 oz/sec valves, Dual transformer 220 VAC primary, 24 VAC secondary, 50/60 Hz, 8" (20.3 cm) cup clearance	110 lbs (49.9 kg)	26"	17.25"	35.625"	\$20,487
00915833	MODEL 158EDRHX Wilshire/Dole FFV 3.0 oz/sec valves, Dual transformer, 230 VAC primary, 24 VAC secondary, 50/60 Hz, 8" (20.3 cm) cup clearance	110 lbs (49.9 kg)	26"	17.25"	35.625"	\$12,696

LID HOLDERS

PART NO.	DETAILS	APPROX. SHIP WEIGHT	W	D	H	PRICE (\$)
00210908	VERTICAL CUP LID HOLDER Mounts on top or beside dispensing towers	7 lbs (3.2 kg)	20"	3.25"	8"	\$455
00219219	WAVE STYLE CUP LID HOLDER Mounts on top of 30" wide dispensing towers	12 lbs (5.4 kg)	30"	11.25"	8"	\$955
00218755	KIT WAVE STYLE CUP LID HOLDER Use with Model 138 and 156	10 lbs (4.5 kg)	24.7"	11.1"	7.9"	\$741



INSULATED CONDUIT

2

PART NO.	DETAILS	DIAMETER	PRICE (\$)
MC025016	2 LINE CONDUIT (2) ½" hose, 1" insulation	3.1" (7.9 cm)	\$19
MC045516	4 LINE CONDUIT (4) ½" hose, foil wrap, 1" insulation	3.9" (9.9 cm)	\$24.16
MC055366	5 LINE CONDUIT (4) 1/2" tube, (1) 3/8" tube, foil wrap, 1" insulation	5.7" (14.4 cm)	\$30
MC075386	7 LINE CONDUIT (3) 1/2" tube, (4) 3/8" tube, foil wrap, 1 1/2" insulation	5.1" (12.9 cm)	\$40.69
MC105536	10 LINE CONDUIT (3) 1/2" hose, (7) 3/8" tube, foil wrap, CO2 out wire, 1 3/4" insulation	5.5" (14.0 cm)	\$65
MC105586	10 LINE CONDUIT (3) ½" hose, (7) ½" tube, foil wrap, 1 1/2" insulation	5.7" (14.4 cm)	\$64.30
MC125556	12 LINE CONDUIT (5) ½" hose, (7) ½" tube, foil wrap, CO2 out wire, 1 1/2" insulation	5.5" (14.0 cm)	\$62
MC125586	12 LINE CONDUIT (5) ½" hose, (7) ½" tube, foil wrap, 1 1/2" insulation	5.5" (14.0 cm)	\$66.13
MC145586	14 LINE CONDUIT (5) ½" hose, (9) ½" tube, foil wrap, 1 1/2" insulation	5.5" (14.0 cm)	\$67.81
MC165326	16 LINE CONDUIT (3) ½" hose, (1) ½" tube, (12) ¾" tube, foil wrap, 1" insulation	4.9" (12.4 cm)	\$52
MC165366	16 LINE CONDUIT (16) cabled tube, foil wrap, 1" insulation	5.1" (12.9 cm)	\$63
MC165486	16 LINE CONDUIT (3) 1/2" hose, (13) 3/8" tube, foil wrap, 1" insulation	5.7" (14.4 cm)	\$58.82
MC175326	17 LINE CONDUIT (14) 3/8" tube, (3) 1/2" hose, foil wrap, 1" insulation	4.9" (12.4 cm)	\$55.26
MC205306	20 LINE CONDUIT (10) ½" hose, (10) ¾" tube, foil wrap, ¾" insulation	5.1" (12.9 cm)	\$59.21

NOTE: Custom conduit configurations available for orders of 1000 ft. minimum.

NOTE: Maximum continuous double insulated conduit lengths as follows:

- 7 lines or less: 300 ft. continuous
- 8-13 lines: 200 ft. continuous
- 14 lines or more: 150 ft. continuous

NOTE: 25 foot minimum order with 15 foot increments.



AMBIENT CONDUIT

2

PART NO.	DETAILS	DIAMETER	PRICE (\$)
MC053396	5 LINE CONDUIT (5) 3/8" tube, no insulation	1.5" (3.8 cm)	\$14.65
MC063396	6 LINE CONDUIT (6) 3/8" tube, no insulation	1.5" (3.8 cm)	\$16.56
MC103396	10 LINE CONDUIT (10) 3/8" tube, no insulation	2.0" (5.1 cm)	\$17.61
MC123396	12 LINE CONDUIT (12) 3/8" tube, no insulation	2.5" (6.3 cm)	\$21.72
MC143396	14 LINE CONDUIT (14) 3/8" tube, no insulation	1.7" (4.3 cm)	\$29.13

NOTE: Custom conduit configurations available for orders of 1000 ft. minimum.

NOTE: Maximum continuous double insulated conduit lengths as follows:

- 7 lines or less: 300 ft. continuous
- 8-13 lines: 200 ft. continuous
- 14 lines or more: 150 ft. continuous

NOTE: 25 foot minimum order with 15 foot increments.

CONDUIT ACCESSORIES

PART NO.	DETAILS	APPROX. SHIP WEIGHT	PRICE (\$)
00208609	CONDUIT TEE KIT For conduit with 3/8" water and 3/8" syrup lines Includes (11) 3/8" tees, (2) 3/8" elbows and insulation	3 lbs (1.4 kg)	\$359
00208610	CONDUIT TEE KIT For conduit with 1/2" water and 3/8" syrup lines Includes (16) 3/8" tees, (4) 1/2" elbows and insulation	3 lbs (1.4 kg)	\$760
00205801	CONDUIT TEE KIT For conduit with 1/2" water and 1/2" syrup lines Includes (14) 1/2" tees, (4) 1/2" elbows and insulation	5 lbs (2.3 kg)	\$760
00217206	CONDUIT ADAPTER KIT Includes (10) 3/8" x 1/4" splicers, insulation, tape and tab clamps	5 lbs (2.3 kg)	\$251
00217205	CONDUIT ADAPTER KIT Includes (10) 1/2" x 1/4" splicers, insulation, tape and tab clamps	5 lbs (2.3 kg)	\$341
00217207	CONDUIT ADAPTER KIT Includes (10) 1/2" x 3/8" splicers, insulation, tape and tab clamps	5 lbs (2.3 kg)	\$256
00205968	LARGE CONDUIT STRAP KIT (5) straps, for conduit with 11 or more lines	3.5 lbs (1.6 kg)	\$243

REFRIGERATION UNITS

EQUIPMENT	PART NO.	DETAILS	APPROX. SHIP WEIGHT	PRICE (\$)
-----------	----------	---------	---------------------	------------

SODA FACTORY MODEL 2803



Shown with optional 6" Leg Kit (00761810)

SS902850-161	MODEL 2803A04 Air-Cooled, 120 VAC/60 Hz/1 Ph, 20.3 Amp	153 lbs (69.3 kg)	\$8,764
---------------------	--	----------------------	----------------

SODA FACTORY MODEL 11



Shown with optional 6" Leg Kit (00761810)

SS901120-161	MODEL 11MA04 Air-Cooled, 120 VAC/60 Hz/1 Ph, 21.5 Amp	204 lbs (92.5 kg)	\$10,568
00217910	SYRUP COIL KIT Model 11, Up to 2 additional coils may be added	1 lb (.5 kg)	\$173

SODA FACTORY MODEL 11



Shown with optional 6" Leg Kit (00761810)

TS904480G-261	ICECORE 44GA04 Air-Cooled, 208/230 VAC/60 Hz/1 Ph, 20 Amp	352 lbs (159.6 kg)	\$15,448
TS904496G-251	MODEL 44GAX04 Air-Cooled, TUV approved carbonator tank 230 VAC/50 Hz/1 Ph, 22 Amp	348 lbs (157.8 kg)	\$15,901
TS904482G-261	ICECORE 44GW04 Water-Cooled, 208/230 VAC/60 Hz/1 Ph, 20 Amp	351 lbs (159.2 kg)	\$16,201
TS904498G-251	ICECORE 44GWX04 Water-Cooled, TUV approved carbonator tank 230 VAC/50 Hz/1 Ph, 22 Amp	334 lbs (151.5 kg)	\$16,675
TS904481G-261	ICECORE 44GR04 Remote Condenser, High-volume, priority carbonation system, 208/230 VAC/60 Hz/1 Ph, 20 Amp	362 lbs (164.2 kg)	\$15,901
TS904497G-251	ICECORE 44GRX04 Remote Condenser, TUV approved carbonator tank 230 VAC/50 Hz/1 Ph, 22 Amp	360 lbs (163.2 kg)	\$16,675
00216680	SYRUP COIL KIT Icecore 44G	15 lbs (6.8 kg)	\$198

EQUIPMENT	PART NO.	DETAILS	APPROX. SHIP WEIGHT	PRICE (\$)
ICECORE MODEL 50G				
 <p>Shown with optional 6" Leg Kit (00761810)</p> <p>30% REDUCTION IN ENERGY USE!</p>	TS905050G-263	ICECORE 50GA04 Air-Cooled 208/230 VAC/60 Hz/3 Ph, 25.5 Amp	399 lbs (180.9 kg)	\$19,098
	TS905053G-353	ICECORE 50GAX04 Air-Cooled 340/440 VAC/50 Hz/3 Ph, 22 Amp	386 lbs (175 kg)	\$20,437
	TS905051G-263	ICECORE 50GR04 Remote Condenser 208/230 VAC/60 Hz/3 Ph, 25.5 Amp	397 lbs (180 kg)	\$19,672
	TS905054G-353	ICECORE 50GRX04 Remote Condenser 340/440 VAC/50 Hz/3 Ph, 16 Amp	383 lbs (173.7 kg)	\$21,167
	TS905052G-263	ICECORE 50GW04 Water-Cooled 208/230 VAC/60 Hz/3 Ph, 25.5 Amp	395 lbs (179.2 kg)	\$20,053
	00216835	SYRUP COIL KIT Model 50 & Icecore 50G Up to 6 additional coils may be added	15 lbs (6.8 kg)	\$198
	TS905046G-263	ICECORE 50MR04 - 24 COILS Remote Condenser 230 VAC/60 Hz 3 Ph, 25.5 Amp	399 lbs (180.9 kg)	\$21,903
	00215715	EXTENSION ASSEMBLY FOR LARGE CONDUIT Model 50 & Icecore 50G		\$859

REFRIGERATION UNITS (CONTINUED)

PART NO.	DETAILS	APPROX. SHIP WEIGHT	PRICE (\$)
MODEL SC180			
SS902829-161	MODEL SC180A04 Air-Cooled, 120 VAC/60 Hz/1 Ph	130 lbs (59.0 kg)	\$7,173
MODEL SC340			
SS901129-161	MODEL SC340A04 Air-Cooled, 120 VAC/60 Hz/1 Ph	160 lbs (72.5 kg)	\$7,970
MODEL SC1000			
TS904460E-261	MODEL SC1000A Air-Cooled, 208/230 VAC/60 Hz/1 Ph, 15 Amp	276 lbs (125.1 kg)	\$11,859
MODEL SC2000			
TS905060E-263	MODEL SC2000A04 Air-Cooled, 208/230 VAC/60 Hz/3 Ph, 25.5 Amp	318 lbs (144.2 kg)	\$15,899
TS905061E-263	MODEL SC2000R04 Remote Condenser, 208/230 VAC/60 Hz/3 Ph, 25.5 Amp	321 lbs (145.6 kg)	\$16,375

PART NO.	DETAILS	APPROX. SHIP WEIGHT	PRICE (\$)
REFRIGERATION UNITS OPTIONS			
00214400	CIRCULATING PUMP KIT Models SC180, SC340 and SC1000	35 lbs (15.9 kg)	\$1,319
00218575	CIRCULATING PUMP KIT Model SC20000 only	35 lbs (15.9 kg)	\$1,441
00214401	PRE-CHILLER INSTALLATION KIT All Super Chiller models	15 lbs (6.8 kg)	\$636

REFRIGERATION UNITS ACCESSORIES			
00761810	6" (15.2 CM) LEG KIT	35 lbs (15.9 kg)	\$199
TS0895-271	For use with Model 44MR, Icecore 44MR, Model 50MR, Icecore 50MR, SC2000R, and all Beermaster™ Units	35 lbs (15.9 kg)	\$3,109
RT20R404	LINE SET R404a 20 ft	10 lbs	Call for Pricing
RT35R404	LINE SET R404a 35 ft	15 lbs	Call for Pricing
RT50R404	LINE SET R404a 50 ft	22 lbs	Call for Pricing

WALL MOUNT SHELVES			
00214299	WALL MOUNT SHELF Stainless steel, supports Soda Factory Model 2803 or Super Chiller Model SC180	35 lbs (15.9 kg)	\$652
SS206730	WALL MOUNT SHELF Stainless steel, supports Soda Factory Model 11 or Super Chiller Model SC340	45 lbs (20.4 kg)	\$801

SUPPORT STANDS				
	00445009	MODEL 4450 SUPPORT STAND with shelves to hold 9 BIB boxes 39½" (H) x 42" (W) x 28" (D) 100 cm (H) x 106.7 cm (W) x 71.1 cm (D)	250 lbs (113.3 kg)	\$2,872
	00445012	MODEL 4450 SUPPORT STAND with shelves to hold 12 BIB boxes 54" (H) x 42" (W) x 28" (D) 137.2 cm (H) x 106.7 cm (W) x 71.1 cm (D)	162 lbs (73.4 kg)	\$3,368

PART NO.	DETAILS	APPROX. SHIP WEIGHT	PRICE (\$)
CONTROL PANELS AND WATER REGULATORS			
00215569	BULK CO2 CONTROLS FOR BAG-IN-BOX Mounts on wall or refrigeration unit. Includes panel, single tank mounted regulator. No CO2 alarm.	12 lbs (5.4 kg)	\$1,273
00215757	CO2 CONTROLS FOR BAG-IN-BOX Mounts on wall or refrigeration unit. Includes panel, dual tank mounted regulators. No CO2 alarm.	14 lbs (6.3 kg)	\$1,501
00206959	CO2 CONTROLS FOR SYRUP TANKS Mounts on wall or refrigeration unit. Includes panel, out of CO2 alarm, dual tank-mounted regulators and air/CO2 changeover valve. Does not include syrup disconnects. 220 VAC	16 lbs (7.2 kg)	\$2,898
00683129	WATER SUPPLY REGULATOR for incoming water pressures greater than 70 psi (4.8 bar)	3 lbs (1.3 kg)	\$409

BAG-IN-BOX PUMP PANELS			
00219056	TWO PUMP PANEL Includes mounting panel, (2) Flojet BIB syrup pumps and (2) QcD BIB connectors	15 lbs (6.8 kg)	\$706
00216563	THREE PUMP PANEL Includes mounting panel, (3) Flojet BIB syrup pumps, (3) changeover valves, (6) Coke screw-type BIB connectors. 230 VAC/50 Hz/1 Ph, 22 Amp	25 lbs (11.3 kg)	\$1,405
00216045	THREE PUMP PANEL Includes mounting panel, (3) Flojet BIB syrup pumps and (3) QcD BIB connectors	20 lbs (9.1 kg)	\$1,083
00214281	THREE PUMP PANEL Includes mounting panel, (3) SHURflo BIB syrup pumps, (3) changeover valves and (6) Coke screw-type BIB connectors	12 lbs (5.4 kg)	\$1,550
00217225	THREE PUMP PANEL Includes mounting panel, (3) Coke screw-type BIB connectors	10 lbs (4.5 kg)	\$1,064

PART NO.	DETAILS	APPROX. SHIP WEIGHT	PRICE (\$)
WATER BOOSTERS			
00215639	MODEL WBK10 120 VAC/60 Hz/1 Ph/5.6 Amp	68 lbs (30.8 kg)	\$3,011
00216382	MODEL WBK10X 220 VAC/50 Hz/1 Ph/2.8 Amp	68 lbs (30.8 kg)	\$3,011
AIR COMPRESSORS			
00214970	MODEL APH3 120 VAC/60 Hz/1 Ph/5.6 Amp	50 lbs (22.7 kg)	\$2,869
00214972	MODEL APH3X 220 VAC/50 Hz/1 Ph/2.8 Amp	50 lbs (22.7 kg)	\$2,761
5031021	AUTOMATIC DRAIN KIT	5 lbs (2.3 kg)	\$474
00212506	AIR COMPRESSOR INSTALLATION KIT Plastic Lines	5 lbs (2.3 kg)	\$214

BEER CONDUITS

PART NO.	DETAILS	APPROX. SHIP WEIGHT	PRICE (\$)
MC023346	TWO LINE GLYCOL ONLY CONDUIT Two Glycol Lines	.5 lbs (.2 kg)	\$21.55

HIGH PERFORMANCE BEER CONDUITS WITH SUPERIOR CLEANABILITY

PART NO.	DETAILS	APPROX. SHIP WEIGHT	PRICE (\$)
MC043346	FOUR LINE BEER CONDUIT Two Beer Lines, Two Glycol Lines	.5 lbs (.2 kg)	\$22.34/ft.
MC053346	FIVE LINE BEER CONDUIT Three Beer Lines, Two Glycol Lines	.5 lbs (.2 kg)	\$24.97/ft.
MC063346	SIX LINE BEER CONDUIT Four Beer Lines, Two Glycol Lines	.8 lbs (.4 kg)	\$26.80/ft.
MC083346	EIGHT LINE BEER CONDUIT Six Beer Lines, Two Glycol Lines	.8 lbs (.4 kg)	\$32.75/ft.
MC123346	TWELVE LINE BEER CONDUIT Eight Beer Lines, Four Glycol Lines	1 lbs (0.5 kg)	\$43.59/ft.
MC143346	FOURTEEN LINE BEER CONDUIT Ten Beer Lines, Four Glycol Lines	1 lbs (0.5 kg)	\$45.99/ft.
MC163346	SIXTEEN LINE BEER CONDUIT Twelve Beer Lines, Four Glycol Lines	1 lbs (0.5 kg)	\$49/ft.

BEER INSTALLATION KITS

PART NO.	DETAILS	APPROX. SHIP WEIGHT	PRICE (\$)
SMALL			
00211505	KIT, SMALL CONDUIT INSTALLATION FITTINGS Use with up to ten faucets. Includes 29 Unions, eight Elbows, three U-bends, 80 Covers, five Tailpieces, five Nuts, one Roll Foil Tape, one Roll PVC Tape, and one Faucet Wrench. Use for up to ten faucets (total), and up to three towers with no more than ten total faucets.	5 lbs (2.3 kg)	\$989

LARGE			
00211507	KIT, LARGE CONDUIT INSTALLATION FITTINGS Use with up to thirteen faucets. Includes 42 Unions, 15 Elbows, four U-bends, 100 Covers, eight Tailpieces, eight Nuts, two rolls Foil Tape, one roll PVC Tape, and one Faucet Wrench. Use for up to thirteen faucets (total), and up to four towers with no more than thirteen total faucets.	6 lbs (2.7 kg)	\$1,421

BEERMASTER™ GLYCOL CHILLER UNITS

PART NO.	DETAILS	APPROX. SHIP WEIGHT	W	D	H	PRICE (\$)
S0907531-161	MODEL 75A04 Maintains constant beer temperature up to 75 feet from the beer cooler. Includes one glycol circulating pump. Air-Cooled 120 VAC, 60 Hz, 15 Amp, 1/3 hp, 1 Phase R404A Refrigerant (CFC free 3,400 BTUH net)	107 lbs (48.5 kg)	16.25"	27.75"	14.25"	\$6,044
S0915021-161	MODEL 150A04, AIR COOLED Maintains constant beer temperature up to 150 feet from the beer cooler. Includes one glycol circulating pump. Air-Cooled 120 VAC, 60 Hz, 30 Amp, 1/2 hp, 1 Phase R404A Refrigerant (CFC free 4,250 BTUH net)	182 lbs (82.5 kg)	18.5"	35.5"	21.5"	\$8,410

BEERMASTER™ GLYCOL KITS FOR UNITS

PART NO.	DETAILS	APPROX. SHIP WEIGHT	PRICE (\$)
00214510	KIT, MODEL 75 GLYCOL Contains 3 gallons propylene glycol.	30 lbs (13.6 kg)	\$431
00211268	KIT, MODEL 150 ADDITIONAL CIRCULATION PUMP AND MOTOR (OPTIONAL) Includes tape, insulation, cord with plug, 70 GPH (220 LPH) circulator pump (with 120 VAC motor), circulator discharge cooling tube, and circulator pump pickup tube.	25 lbs (11.3 kg)	\$980
00211306	KIT, MODEL 150 GLYCOL Contains 5 gallons propylene glycol.	47 lbs (21.3 kg)	\$667

BEER PUMPS, PANELS AND ACCESSORIES – BEER PUMPS AND PANELS

PART NO.	DETAILS	WEIGHT	PRICE (\$)
G5612-02E	FLOJET STANDARD BEER PUMP Includes straight brass gas shutoff and 3/8" and 1/2" combination in/out fittings.	1 lbs (.5 kg)	\$225

AIR COMPRESSOR

PART NO.	DETAILS	WEIGHT	PRICE (\$)
00214970	MODEL APH3 AIR COMPRESSOR Includes a 3 gallon tank. Disposable Replacement Air Filter for Air Compressor (P.N. 00201085) requires periodic replacement.	50 lbs (22.7 kg)	\$2,869

BEERMASTER™ ACCESSORIES

EQUIPMENT	PART NO.	DETAILS	WEIGHT	PRICE (\$)
-----------	----------	---------	--------	------------

EMPTY BEER DETECTOR KITS



SF-07

EMPTY BEER DETECTOR WITH "Y" ADAPTOR KIT

2.5 lbs
(1.1 kg)

\$422

CONDUIT HANGAR BRACKETS KITS

00205968

KIT, FIVE LARGE CONDUIT HANGAR BRACKETS

3.5 lbs
(1.6 kg)

\$243

PRODUCT INFORMATION



- EcoBlend® technology featuring the next generation of blending in a cup, which reduces water and product waste.
- Integrated nugget ice maker
- Integrated refrigerated product storage
- 45 drinks/hour
- Intuitive 21.5" touch screen UI
- High performance single blade
- Automated cup shuttle
- Volumetric pump system for improved product consistency and product waste
- Clean in place sanitation system
- Wireless ready
- ADA compliance panel controls
- Locking front casters
- Cloud control and machine monitoring
- Network or USB software update ability

PART NO.	DETAILS	VOLTAGE/CYCLE/ PHASE/AMPS	APPROX. SHIP WEIGHT	W	D	H	PRICE (\$)
FB08ETF-R-GEN1	Fresh Blender® RH General Market EcoBlend®	120/60/1/16	660 lbs	38.79"	20.26"	78.53"	\$49,091.68

N2FUSION™ NITROGEN INFUSION SYSTEM

PRODUCT INFORMATION



- Allows for both still drinks and nitrogenated drinks to be poured from a common source (keg) with its patented in-line nitrogenator, reducing product cost and time (kegs can take up to 14 hours to nitrogenate by traditional infusion methods)
- Nitro dispense creates a true "Theater of the Pour" with a soft, frothy head and a waterfall effect that fascinates customers and drives higher ticket purchases.
- A fully integrated, standalone system requiring just a source of food-grade nitrogen and the beverage you wish to dispense. The refrigerated base insures that product is kept below 41° F for a cool, consistent pour.
- This unit isn't just about coffee! All kinds of beverages, from teas to juices can be infused with nitrogen for a delicious, unique experience that customers will share online with friends.
- 2 taps, drip pan

PART NO.	DETAILS	VOLTAGE/CYCLE/ PHASE/AMPS	APPROX. SHIP WEIGHT	W	D	H	PRICE (\$)
REMOTE TOWER SYSTEM							
ND21RS00	Remote Tower System	115/60/1/6	168 lbs	27.3"	28.4"	44.6"	\$19,634
ND21RS00B	Remote Tower System	115/60/1/6	168 lbs	27.3"	28.4"	44.6"	\$19,634

Equipment does not include regulator, if your configuration requires a regulator the part number is 3239832

ACCESSORIES AND MODIFICATIONS

AS3547976	Keg						\$517
------------------	-----	--	--	--	--	--	--------------

N2MOBILE™ NITROGEN INFUSION SYSTEM



PRODUCT INFORMATION

- N2Mobile is a unique solution for your cold brew, nitro and iced coffee needs. By combining an innovative cooler design, on-board nitrogen storage and in-line infusion, cafe quality nitro coffee is now more accessible than ever before!

PART NO.	DETAILS	VOLTAGE/CYCLE/ PHASE/AMPS	APPROX. SHIP WEIGHT	W	D	H	PRICE (\$)
N2MOBILE™							
ND21TS59	Mobile standalone system	n/a	168 lbs	17.1"	17.1"	49.1"	\$6,576

SCAN THE CODE BELOW TO LOCATE A DEALER, DISTRIBUTOR
OR SALES REPRESENTATIVE IN YOUR AREA.



OR GO TO
WWW.MULTIPLEXBEVERAGE.COM/SALES/SALES-LOCATORS

